

OXYTHERM[®] FHR Dual Fuel Burners

TECHNICAL CATALOG

FEATURES AND BENEFITS

- Industry lowest NOx levels
- Adjustable staged oxygen design to optimize heat transfer, flame volume and emissions
- Burns any gaseous fuel
- Fuel oil capability ranges from light to heavy fuel oils
- Quickly convert between gas and oil service by changing the fuel nozzle only
- Capacities to 24 MBtu/hr
- Increase available heat by burning fuels with oxygen

PRODUCT DESCRIPTION

With OXYTHERM[®] FHR burners firing gas, fuel gas and oxygen for combustion enter the burner housing and mix at the nozzle exit.

For oil firing, the oil enters through the nozzle, is atomized with compressed air, then combines with the combustion oxygen as it exits the burner block.

The oxygen-fuel flame discharges through the refractory block tunnel to create a high aspect ratio, flat flame pattern.

APPLICATIONS

OXYTHERM[®] FHR burners reduce fuel consumption in high temperature (>1400°F) applications. The higher flame temperature of oxy-fuel firing increases the available heat and radiant heat transfer to most applications. Typical improvements include increased thermal efficiency, increased processing rates, higher product quality, reduced flue gas volumes and reduced pollutant emissions.

OXYTHERM[®] burners have been successfully applied to glass furnaces, day tanks, incinerators, metal melting furnaces, linear and rotary hearth furnaces, reheat furnaces, kilns, and many other types of high temperature (>1400°F) applications.

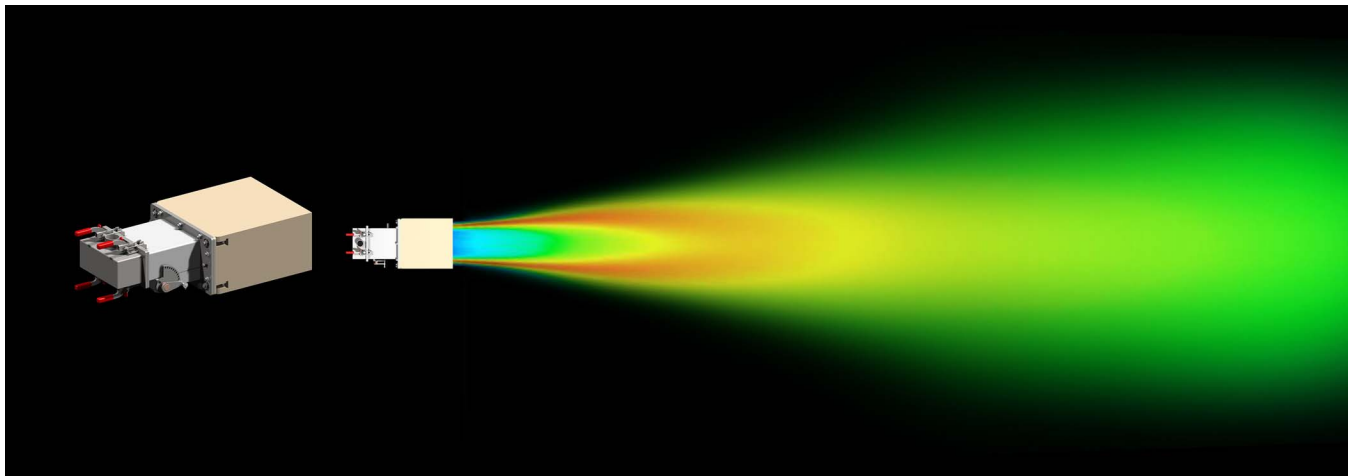

MODEL NUMBER

OXYTHERM® FHR gas burners

Burner model	Burner size	Burner type	Fuel	Fuel flow	Block material	Burner block	Oil conversion kit	Tagging
OT FHR	S	G	N	36	Z	Y	N	N

Burner model

OT FHR - OXYTHERM® FHR burner

Burner size

S - Small
M - Medium
L - Large
XL - Extra large

Burner type

G - Gas

Fuel

N - Natural gas
X - Special gas (see Engineering)

Fuel flow

For OT FHR S G burners:
36 - 36 cubic meters/h
43 - 43 cubic meters/h
50 - 50 cubic meters/h
56 - 56 cubic meters/h
65 - 65 cubic meters/h
82 - 82 cubic meters/h

For OT FHR M G burners:
81 - 81 cubic meters/h
103 - 103 cubic meters/h
113 - 113 cubic meters/h
124 - 124 cubic meters/h
161 - 161 cubic meters/h

For OT FHR L G burners:
170 - 170 cubic meters/h
187 - 187 cubic meters/h
204 - 204 cubic meters/h
266 - 266 cubic meters/h
339 - 339 cubic meters/h

For OT FHR XL G burners:
281 - 281 cubic meters/h
365 - 365 cubic meters/h
466 - 466 cubic meters/h
566 - 566 cubic meters/h
667 - 667 cubic meters/h

Block material

M - MFZ-6 Mullite
Z - Zedpave

Burner block

Y - Yes
N - No

Oil conversion kit

For OT FHR S G burners:
N - None
41 - 41 liters/h
58 - 58 liters/h
68 - 68 liters/h

For OT FHR M G burners:
N - None
99 - 99 liters/h
134 - 134 liters/h
193 - 193 liters/h

For OT FHR L G burners:
N - None
217 - 217 liters/h
251 - 251 liters/h
313 - 313 liters/h
358 - 358 liters/h

For OT FHR XL G burners:
N - None
462 - 462 liters/h
500 - 500 liters/h
569 - 569 liters/h

Tagging
N - None
ALW - Aluminum (wire-on)
SSW - Stainless steel (wire-on)

OXYTHERM® FHR oil burners

Burner model	Burner size	Burner type	Fuel	Fuel flow	Block material	Burner block	Gas conversion kit	Tagging
OT FHR	S	O	L	41	Z	Y	N	N

Burner model

OT FHR - OXYTHERM® FHR burner

Burner size

S - Small
M - Medium
L - Large
XL - Extra large

Burner type

O - Oil

Fuel

L - Light fuel oil
H - Heavy fuel oil

Fuel flow

For OT FHR S O burners:

41 - 41 liters/h
58 - 58 liters/h
68 - 68 liters/h

For OT FHR M O burners:

99 - 99 liters/h
134 - 134 liters/h
193 - 193 liters/h

For OT FHR L O burners:

217 - 217 liters/h
251 - 251 liters/h
313 - 313 liters/h
358 - 358 liters/h

For OT FHR XL O burners:

462 - 462 liters/h
500 - 500 liters/h
569 - 569 liters/h

Block material

M - MFZ-6 Mullite
Z - Zedpave

Burner block

Y - Yes
N - No

Gas conversion kit

For OT FHR S O burners:

N - None
36 - 36 cubic meters/h
43 - 43 cubic meters/h
50 - 50 cubic meters/h
56 - 56 cubic meters/h
65 - 65 cubic meters/h
82 - 82 cubic meters/h

For OT FHR M O burners:

N - None
81 - 81 cubic meters/h
103 - 103 cubic meters/h
113 - 113 cubic meters/h
124 - 124 cubic meters/h
161 - 161 cubic meters/h

For OT FHR L O burners:

N - None
170 - 170 cubic meters/h
187 - 187 cubic meters/h
204 - 204 cubic meters/h
266 - 266 cubic meters/h
339 - 339 cubic meters/h

For OT FHR XL O burners:

N - None
281 - 281 cubic meters/h
365 - 365 cubic meters/h
466 - 466 cubic meters/h
566 - 566 cubic meters/h
667 - 667 cubic meters/h

Tagging

N - None
ALW - Aluminum (wire-on)
SSW - Stainless steel (wire-on)

SPECIFICATIONS

Capacities

OXYTHERM® FHR gas burners

Typical burner data					
Fuel: natural gas at 60°F with 1000 Btu/ft³ (st) HHV - sg = 0.6 [1]					
propane at 60°F with 2500 Btu/ft ³ HHV - sg 1.57 [1]					
Stated pressures are indicative. Actual pressures are a function of air humidity, altitude, type of fuel and gas quality.					
OXYTHERM® FHR gas burners		OXYTHERM® FHR gas burner size			
		Small (S)	Medium (M)	Large (L)	Extra Large (XL)
Maximum capacity range	MBtu/h	1.0 - 3.2	2.9 - 6.3	6.0 - 13.1	10.0 - 24.0
Turndown		3 to 1			
Pressures required to burner inlet for maximum capacities	Oxygen (@ 50% staged)	< 1.0 psig	< 1.0 psig	< 1.0 psig	< 1.4 psig
	Natural gas psig	1.2			
	Propane psig	2.5			
Typical oxygen to fuel volumetric ratios	To natural gas	2.05 to 1			
	To propane	5.1 to 1			
Approximate flame size	Length	See graphs on page 7			

[1] sg (specific gravity) = relative density to air (density air = 0.0763 lb/ft³ (st))

(See Application Engineering Data Sheet for OXYTHERM® FHR burners for specific oxygen pressure information.)

OXYTHERM® FHR oil burners

OXYTHERM® FHR oil burners		(LFO) = Light Fuel Oil; (HFO) = Heavy Fuel Oil [1]												
Housing size		Small (S)			Medium (M)			Large (L)				Extra Large (XL)		
Oil nozzle		115	125	156	188	218	250	281	312	328	344	391	422	438
Maximum flow	gallons/hr	10.8	15.4	17.9	26.2	35.3	50.9	57.4	66.4	82.7	94.6	122.2	132.2	150.3
Fuel oil pressure @ maximum (LFO)	psig	75												
Fuel oil pressure @ maximum (HFO)	psig	95.0												
Turndown		3 to 1												
Atomizing pressure (LFO)	psig	60												
Atomizing pressure (HFO)	psig	80												
Flame length range @ maximum	feet	4-5.5	4-5.5	4.5-6	5-6.5	5-6.5	8-10	10-12	10-12	11-13	12-14	13-15	14-16	15-17

[1] Heavy fuel oils require heating to obtain proper viscosity (less than 100 SSU or 21 cs) for optimal atomization. Temperature of HFO should be measured at burner inlet, not HFO storage tank or oil heater outlet.

(See Application Engineering Data Sheet for OXYTHERM® FHR burners for specific oil pressure information.)

NOTE: Burner fuel oil insert and oil piping near the fuel inlet should be purged with compressed air after shut down to clear any remaining fuel oil. Failure to do so may cause plugging of oil atomizer and nozzle, and cause poor or improper performance.

MATERIALS OF CONSTRUCTION

Burner part	Material
Burner housing	304 stainless steel
Block	Zedpave (default) or MFZ-6 Mullite
Gas nozzle	446 stainless steel
Oil nozzle	446 stainless steel
Mounting gasket	MICA composite 710-1

INTENDED SERVICE AND TYPICAL APPLICATION

Application details

OXYTHERM® FHR burners can be used in furnaces and melters, steel reheat furnaces, linear hearth furnaces, rotary hearth furnaces, reverberatory furnaces, and other high temperature applications.

OXYTHERM® FHR burners have a unique design which allows fuel interchangeability and easy maintenance. They are able to operate on fuel gas, light fuel oils or heavy fuel oils. Each fuel requires the use of separate nozzle inserts. Following plant safety procedures, the burner fuel inserts can be removed while the furnace is still in operation. In some cases, fuel oils may be atomized by fuel gases allowing simultaneous firing of two fuels.

OXYTHERM® FHR fuel inserts are custom designed for specific flame sizes and capacities. Contact MAXON with information on your furnace dimensions, process, and capacity requirements.

⚠ WARNING
Consult the installation and operation manual for safe removal of burner inserts. Use caution as hot furnace gases will be present around typical burner installations.

Fuels

OXYTHERM® FHR burners are designed for firing on any clean fuel gas or light and heavy fuel oils.

Process flows and oxygen content

OXYTHERM® FHR burner requires no additional oxygen for complete, clean combustion beyond the oxygen fed through the burner oxygen connection.

Process temperatures

OXYTHERM® FHR burners may be applied to furnace temperatures up to 3050°F with standard block materials. For higher temperatures, please contact MAXON regarding special block materials.

Cooling flow, either clean, dry air or oxygen, must be used whenever the burner assembly is in a high temperature atmosphere and is not firing. See installation and operating instructions for more details.

⚠ WARNING
Staged oxygen control valve must be placed in position #1 as shown on page 6 to provide optimal cooling to the burner.

Burner blocks

Zedpave or MFZ-6 Mullite burner blocks are used with gas firing and oil firing. Burner blocks are available in standard lengths. See “Dimensions and weights” on page 8.

Block material type	Maximum temperature
MFZ-6 Mullite	3050°F
Zedpave	3050°F

Ratio control requirements

Correct fuel/oxygen ratio control valves should be selected. Trims should be selected to enable use with oxygen. For accurate ratio control, MAXON SMARTLINK® MRV valves are recommended. Calibrated flowmeters in the fuel and the oxygen lines are required for establishing accurate volumetric flow rates.

⚠ WARNING
Oxy-fuel burners cannot be set up and operated properly using only pressure measurements for adjustment. Fully metered oxygen and fuel control systems are required for safe and optimum performance.

Emission performance

OXYTHERM® FHR burners utilize a patented oxygen staging technology to reduce the formation of NOx in high temperature furnaces. Through deep staging of the oxidant flow, NOx is controlled to levels typically lower than less advanced oxy-fuel burners.

Best results are achieved in furnaces which are sealed tight from ambient air infiltration or running a slight positive pressure to prevent the infiltration of nitrogen compounds. Results can vary widely by application. Contact MAXON for estimates and consultation on best practice.

Exact emissions performance may vary in your application. Contact MAXON for installation-specific estimates and guaranteed values. No guarantee of emissions is intended or implied without specific, written guarantee from MAXON.

Combustion oxygen and cooling flow

OXYTHERM® FHR burners may be adjusted to operate on ratio, with excess oxygen (oxidizing environment) or with excess fuel (reducing environment). Typical applications will operate with 1-2% excess oxygen.

If burners are shut down while the furnace remains hot, it is recommended to continue a small flow of oxygen for cooling of the burner. Alternatively, blower or fan air or can be used for burner cooling during burner shut down. Total elimination of cooling flow in hot furnaces can result in damage to burner fuel inserts and other parts. For extended shut downs in hot furnaces, it is recommended that the fuel insert be removed and cooling flow maintained through the burner housing.

Staging ratio control

OXYTHERM® FHR burners feature an adjustable staged oxygen design to optimize heat transfer, flame volume and emissions. Increasing the staged oxygen produces higher radiative heat flux, larger flame volume and lower NO_x emissions; decreasing staged oxygen produces lower radiative heat flux, smaller flame volume and higher NO_x emissions. The numbered hole positions (1-11) shown on the drawing below correspond with the hole positions indicated on the primary/staged oxygen valve adjustment graphs available from your MAXON sales representative.

- 1) Increasing staged oxygen = higher radiative heat flux
- 2) Decreasing staged oxygen = lower radiative heat flux

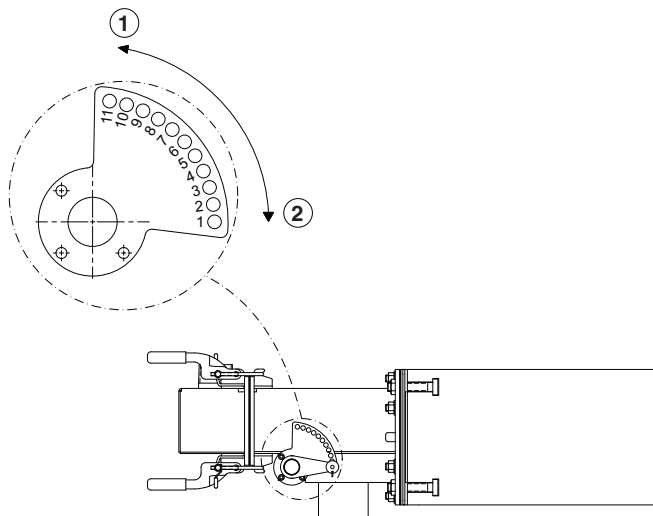

Flame length - gas burners

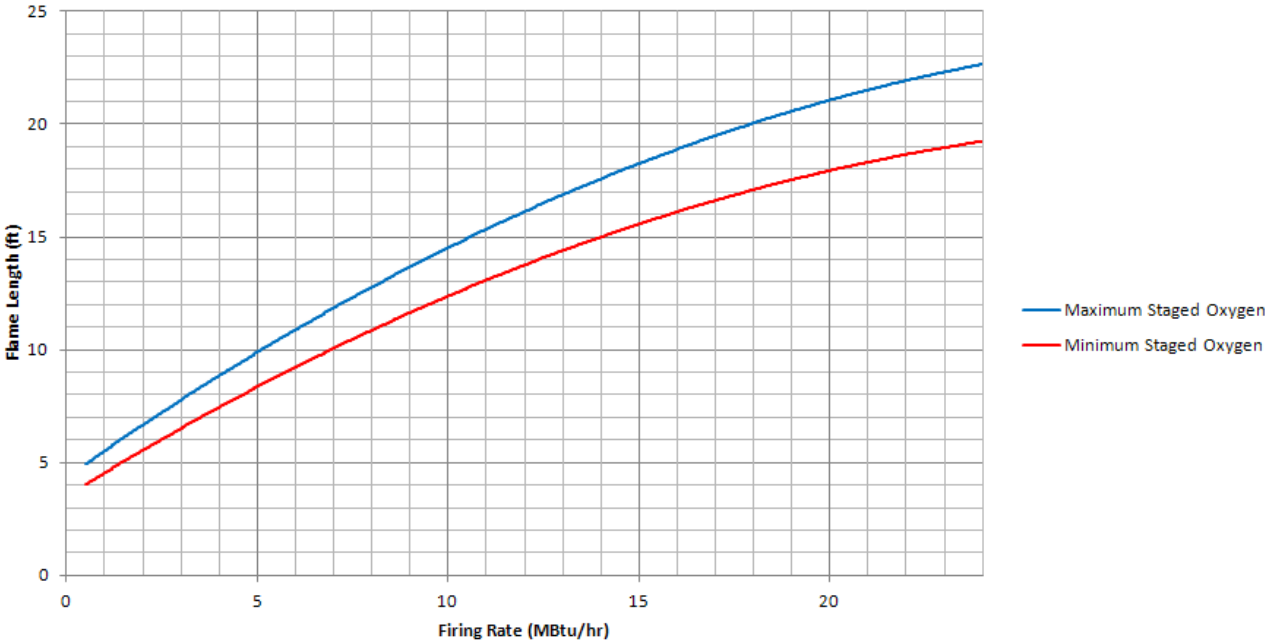

Flame lengths shown are typical for burners sized and operating at maximum design conditions. Flame lengths per unit of heat input will vary from these values when burners are operated below maximum design.

DIMENSIONS AND WEIGHTS

OXYTHERM® FHR gas burners

- 1) 1/4" NPT oxygen pressure tap
- 2) Furnace wall exterior
- 3) Fuel inlet
- 4) Oxygen inlet

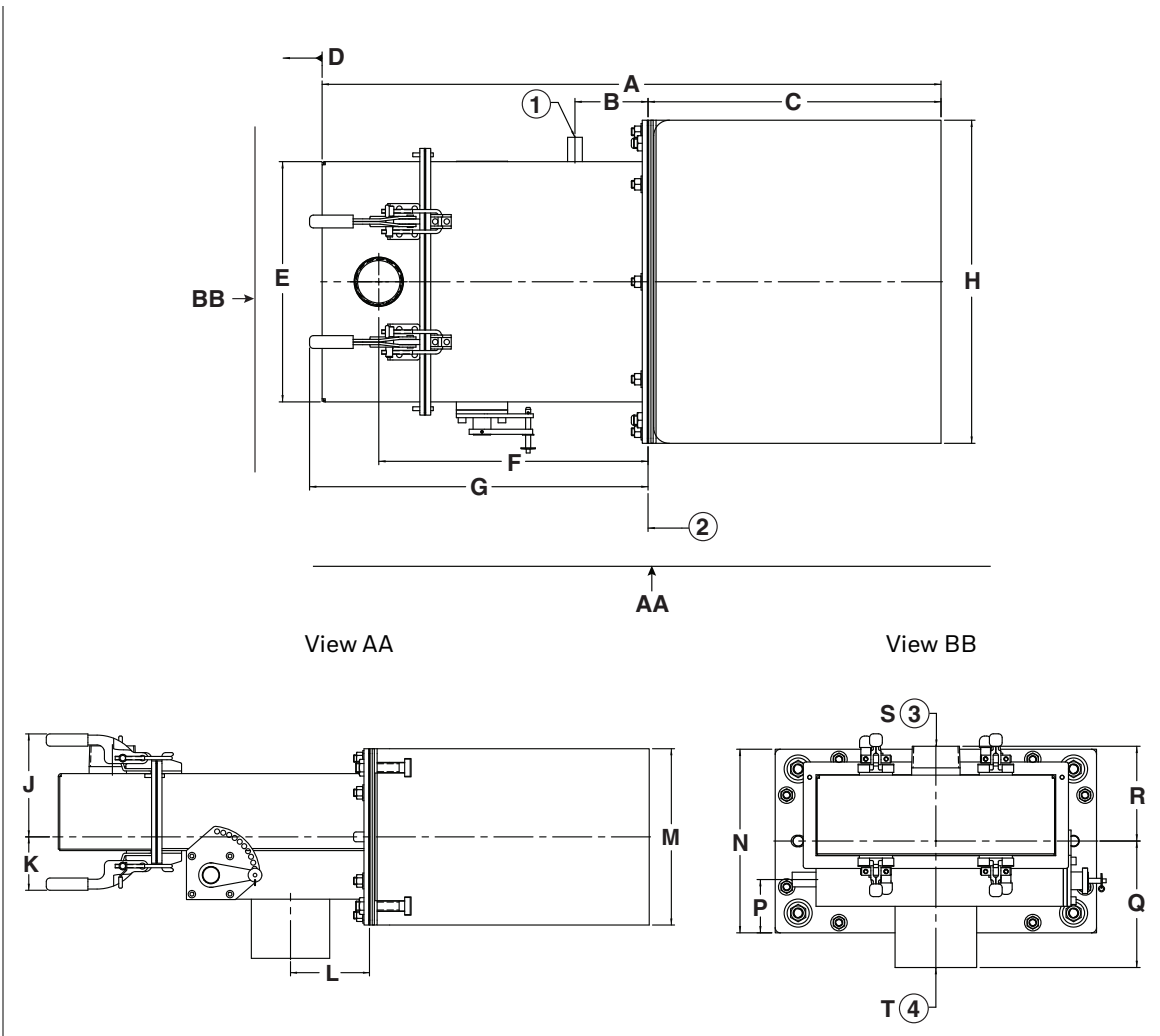

Dimensions in inches unless stated otherwise										
Size	A	B	C	D [1]	E	F	G	H	J	K
S	23.7	2.72	12.28	14.12	5.96	9.41	13.47	10.0	4.26	2.62
M	26.54	2.82	14.28	14.62	8.21	10.22	14.0	13.25	4.73	2.93
L	30.17	3.56	14.28	15.12	11.71	13.12	16.5	15.75	5.26	2.73
XL	33.23	4.22	14.28	16.5	15.65	14.75	18.95	21.75	6.66	3.85

Size	L	M	N	P	Q	R	S NPT	T NPT	Burner weight lbs	Block weight lbs
S	3.03	6.0	6.0	1.81	3.78	3.48	1-1/2	2	80	55
M	3.16	7.5	7.5	2.1	4.4	4.02	1-1/2	2	135	100
L	4.03	9.0	9.0	2.61	6.2	4.64	2	3	195	130
XL	4.62	11.88	11.88	2.93	7.57	6.66	3	4	335	245

[1] Clearance required to remove nozzle

OXYTHERM® FHR oil burners

- 1) 1/4" NPT oxygen pressure tap
- 2) Furnace wall exterior
- 3) 1/2" NPT atomizing air connection
- 4) 1/2" NPT oil connection
- 5) Oxygen inlet

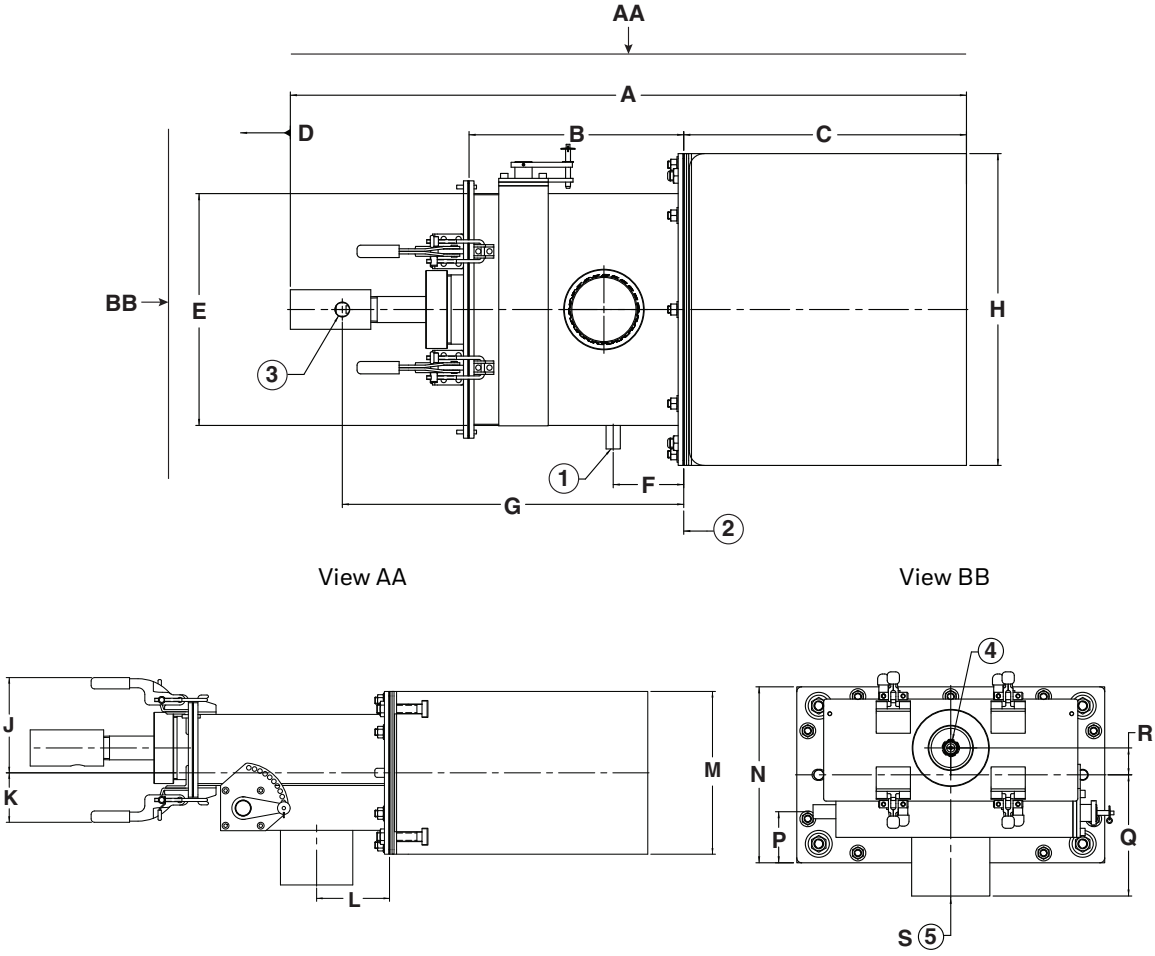

Dimensions in inches unless stated otherwise										
Size	A	B	C	D [1]	E	F	G	H	J	K
S	29.11	7.84	12.28	19.5	5.96	2.72	14.17	10.0	4.27	2.63
M	31.63	8.34	14.28	21.5	8.21	2.82	14.7	13.25	3.54	4.11
L	34.15	10.84	14.28	24.0	11.71	3.56	17.25	15.75	5.27	2.74
XL	35.46	12.16	14.28	24.5	15.65	4.22	18.56	21.75	---	---

Size	L	M	N	P	Q	R	S NPT	Burner weight lbs	Block weight lbs
S	3.03	6.0	6.0	1.81	3.78	.90	2	85	55
M	3.16	7.5	7.5	2.1	4.4	1.19	2	140	100
L	4.03	9.0	9.0	2.61	6.20	1.38	3	200	130
XL	4.62	11.88	11.88	2.93	7.57	1.67	4	335	245

[1] Clearance required to remove nozzle

INSTALLATION INSTRUCTIONS

Please read the operating and mounting instructions before using the equipment. Install the equipment in compliance with the prevailing regulations.

Bedrijfs- en montagehandleiding voor gebruik goed lezen! Apparaat moet volgens de geldende voorschriften worden geïnstalleerd.

Lire les instructions de montage et de service avant utilisation! L'appareil doit impérativement être installé selon les réglementations en vigueur.

Betriebs- und Montageanleitung vor Gebrauch lesen! Gerät muß nach den geltenden Vorschriften installiert werden.

Storage

OXYTHERM® FHR burners shall be stored dry (inside). Burner blocks have been cured carefully before shipment and shall be kept dry. Wetting of the blocks could result in premature failures.

Handling

OXYTHERM® FHR burners are shipped as complete units. Handle burners with care, using proper equipment, during unpacking, transport, lifting and installation. Any impact on the burner could result in damage.

Burner mounting

The views on page 11 show two possible methods for mounting and holding an OXYTHERM® FHR burner block and frame assembly in place.

Typical burner mounting arrangement

- 1) Furnace wall
- 2) Melter wall
- 3) By others
- 4) Piping support by others

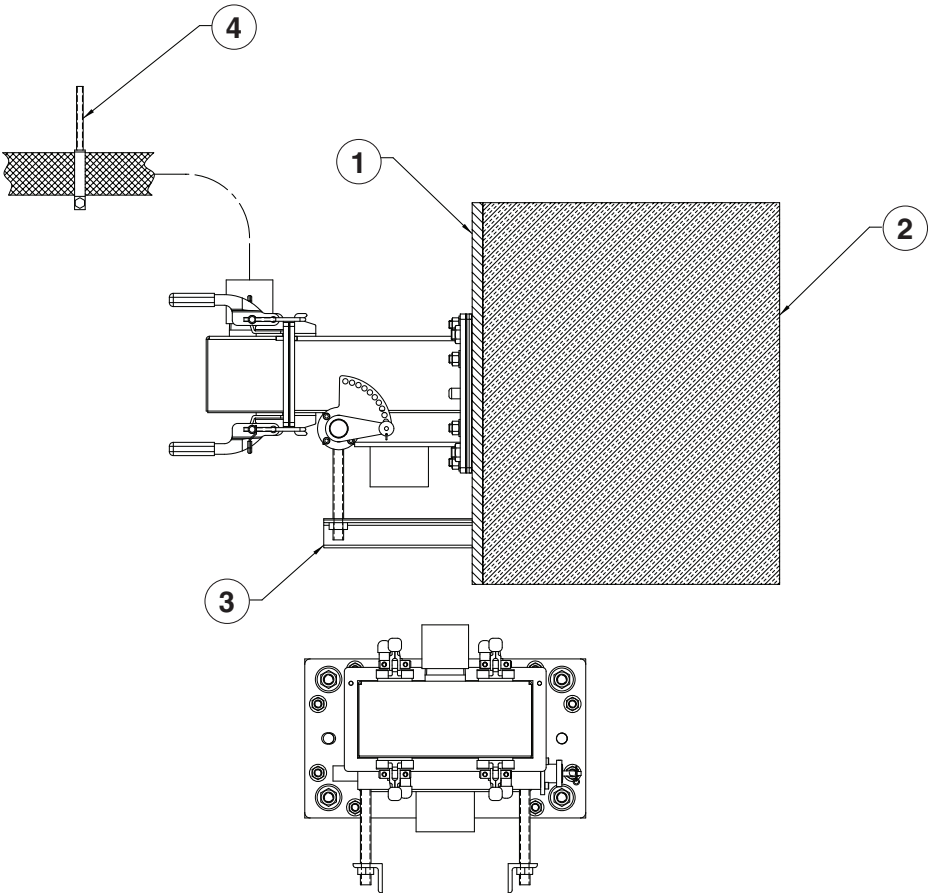

Alternate burner mounting arrangement

- 1) By others

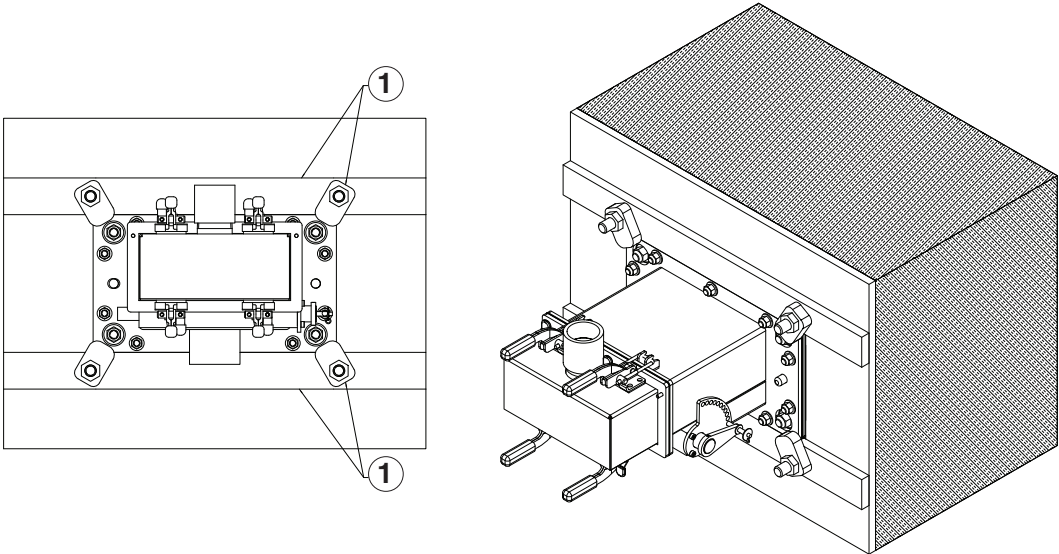

Burners should not be installed in a down-fired position.

The primary objective is to seal the burner block in the wall of the furnace and support the weight of any system piping.

The burner block sits on the sill or wall. The block must rest flat on the sill or wall without rocking to allow weight to be equally distributed. Failure to do so could result in cracking and/or block failure. If burner port holes are too large, appropriate material shims may be used to align the burner.

Burner block failure could result from external forces and stresses transmitted to the burner through the piping. Under no circumstances should burner be the only support for the piping. Flexible connections are recommended in all piping to reduce piping stresses and alignment/shifting problems. Installation of such connectors at certain key spots in the oxygen or gas manifolding can prevent damage to the burners from uneven thermal expansion.

The opening of the furnace wall should provide a minimum of 1/16" clearance on all sides. High temperature furnace sealant or other appropriate material should be used between burner block and furnace wall.

IMPORTANT

For maximum burner life, burner housing and associated parts must be protected from hot gases.

Burner installation procedure

Read the entire installation procedure before proceeding with the installation of oxygen-fuel burners.

⚠ WARNING

Failure to follow the proper installation sequence noted below could result in damage or destruction of vital burner components.

Cooling oxygen or air flows should be present at all times when the burner housing and metal components are mounted to a hot furnace.

To prevent damage in transit, the fuel inserts, mounting gaskets and burner housing may be packed separately. In most cases, the burner will be shipped assembled. The housing may be removed from the burner block mounting plate to allow installation of the block/mounting plate assembly only into the furnace wall.

NOTE: A 3/4" (or 12 mm) socket wrench is required for mounting nuts. A manual speed wrench is recommended for quick and easy mounting of the burner housing.

- If fuel insert is shipped inside burner housing, remove the fuel insert and set aside in a protected area.
- Install service plate over housing flange and secure plate to housing using T-bolts provided.
- Pre-pipe quick-connect devices to the combustion oxygen, fuel and atomizing connections (if required) on the burner housing and burner fuel inserts.
- Install block/plate/housing assembly into furnace wall.
- Establish cooling flow of air or oxygen through the housing during furnace heat up.

⚠ CAUTION

Staged oxygen control valve must be placed in position #1 as shown on page 6 to provide optimal cooling to the burner.

- 1) Service plate
- 2) Cooling flow
- 3) Staged oxygen control valve (set to position #1 for optimal cooling)

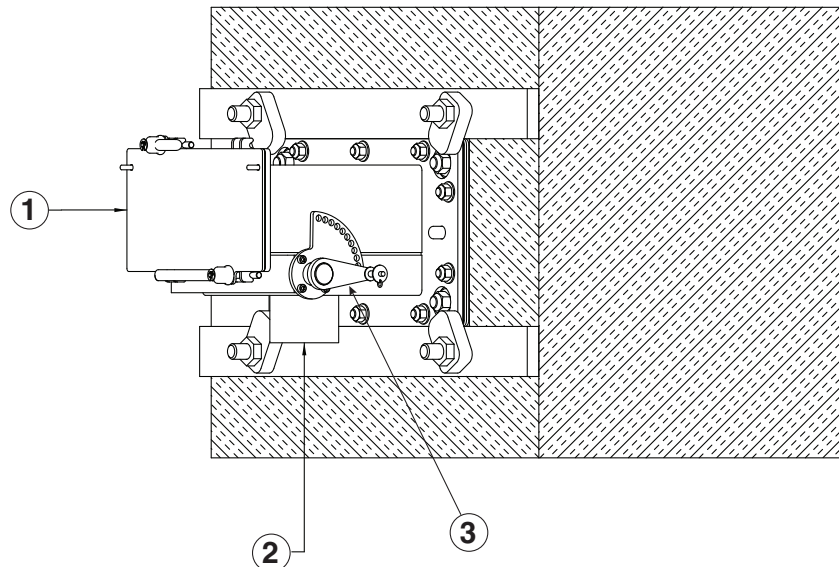

View port

A view port to observe burner flame is essential to inspect flame aspect. Locate the view port downstream of the flame, looking back to the burner block. Make sure the complete flame can be evaluated.

Support burner oxygen and gas piping

The OXYTHERM® FHR burner shall not be used as support for the piping to the burner. Gas and oxygen piping shall be supported in such a way that no additional loads will be created on the burner. Unsupported piping puts stresses on the block/housing assembly.

Flexible connections are typically recommended for all OXYTHERM® FHR installations for both fuel and oxygen to prevent transferring mechanical loads or vibrations to the burner's ceramic parts. Quick connect/disconnect devices are recommended on the oxygen and fuel connections to ease fuel nozzle switching.

OPERATING INSTRUCTIONS

Instructions provided by the company or individual responsible for the manufacture and/or overall installation of a complete system incorporating MAXON burners take precedence over the installation and operating instructions provided by MAXON. If any of the instructions provided by MAXON are in conflict with local codes or regulations, please contact MAXON before initial start-up of equipment.

WARNING

Read the combustion system manual carefully before initiating the start-up and adjustment procedure.

Verify that all of the equipment associated with and necessary to the safe operation of the burner system has been installed correctly, that all pre-commissioning checks have been carried out successfully and that all safety-related aspects of the installation are properly addressed.

Start-up

Typical ignition sequence

IMPORTANT

OXYTHERM® FHR burners do not include means for self ignition. Burner ignition procedure is the responsibility of the end user, according to applicable local, state and national codes. Burner ignition should only be attempted at minimum firing rates (see capacity charts or contact MAXON) to prevent pressure surge in the fired chamber.

Checks during and after start-up

During and after start-up, check the integrity of the system. Check all bolted connections after first firing (first time on temperature) and retighten if necessary.

Burner adjustment and control

Oxygen-fuel burners require accurate control of both fuel and oxygen for optimum performance. Piping to individual burners should include control valves for both oxygen and fuel. In addition, flow meters for oxygen and fuel capable of local or remote readout are required for proper burner adjustment.



CAUTION

Oxygen should only be used with approved materials, properly cleaned pipe and equipment, and specially designed systems.

Ordinary materials can be extremely flammable in the presence of oxygen and air enriched with oxygen.

Oxy-fuel burners cannot be set up and operated properly using only pressure requirements for adjustment. Fully metered oxygen and fuel control systems are required for safe and optimum performance.

MAINTENANCE INSTRUCTIONS



WARNING

The OXYTHERM® FHR burner is provided with quick release clamps to allow for rapid change-over between gas and oil firing.

Customer-specific procedures for shut down and blocking of fuel gas and oxygen supply to the burner must be developed and adhered to prior to attempting removal and changing of fuel inserts. Only trained and qualified service and maintenance personnel should perform this operation.

Safety requirements

Regular inspection, testing and recalibration of combustion equipment according to the installation manual is an integral part of its safety. Inspection activities and frequencies shall be carried out as specified in the installation manual.

Perform the following activities at least annually as part of a recommended preventative maintenance routine:

- Inspect burner internal parts for wear and oxidation.
- Inspect associated control instruments and devices for function with particular attention to all safety permissive switches.
- Perform leak tests on fuel shut-off valves according to any schedule established by the authority having jurisdiction.

Visual inspections

Regular visual inspection of all connections (air and fuel piping to the burner, bolting of the burner to the block) and burner flame size and aspect are essential.

Recommended spare parts

Keep local stock of operationally critical parts. Contact MAXON for a complete list of recommended spare parts for your specific application.

MAXON

201 East 18th Street
P.O. Box 2068
Muncie, IN 47307-0068
www.maxoncorp.com

Maxon reserves the right to alter specifications and data without prior notice.

Automation and Control Solutions

Honeywell International Inc.
1985 Douglas Drive North
Golden Valley, MN 55422
customer.honeywell.com

® U.S. Registered Trademark
© 2016 Honeywell International Inc.
32M-02012-01 M.S. Rev. 06-16
Printed in United States

